

# Bantam Tools EggBot™™ User Guide

## 1. Introduction: Bantam Tools EggBot™ History

The Bantam Tools EggBot™ is a compact drawing machine that produces art on spherical and ovoid (egg-shaped) objects. Unlike printers or cutters that only work on flat surfaces, Bantam Tools EggBot™s are designed to decorate items normally considered “impossible” to print on, such as eggs, golf balls, light bulbs, ping pong balls, mini pumpkins, and holiday ornaments. Highly adjustable and easy to use, Bantam Tools EggBot™s open new possibilities for creativity, education, and play.

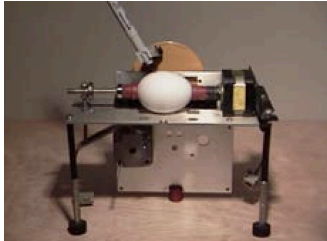

The story of Bantam Tools EggBot™ began in 1990 as a spirited art robot created by motion-control artist Bruce Shapiro, celebrated as the Father of the EggBot. Later nurtured by Evil Mad Scientist and embraced worldwide, EggBots found homes in museums, classrooms, makerspaces, and studios, inspiring artists, educators, and families alike. Now reimagined at Bantam Tools with modern components and a holiday focus, the Bantam Tools EggBot™ is the most precise EggBot yet, carrying forward the tradition of transforming everyday objects into personal works of art.

Left: An early EggBot™

In 2009, Bruce worked with a team to turn an EggBot into a kit for home assembly, which they showed off at that year's Maker Faire.

Right: Kit 2009

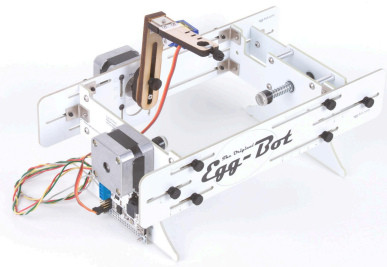
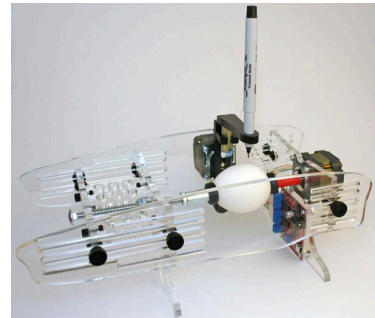

In 2010 in collaboration with Bruce, Windell Oskay and Lenore Edman of Evil Mad Scientist Laboratories introduced a new EggBot™ kit featuring a number of design and material changes that made it more reliable and easier to use.

Left: EggBot™ “2.0” kit, 2010

In 2014, Evil Mad Scientist drew upon the lessons learned over several years of making Bantam Tools EggBot™ kits to make the EggBot™ Pro. The Pro was built from CNC machined aluminum, with quick release adjustments, a ball-bearing tailstock and a new, open geometry, for easier adjustments and better visibility while printing.

Right: Bantam Tools EggBot™ Pro

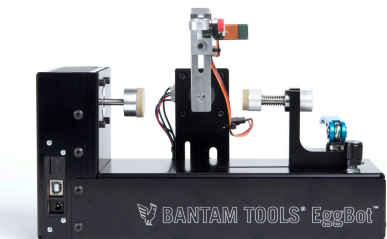
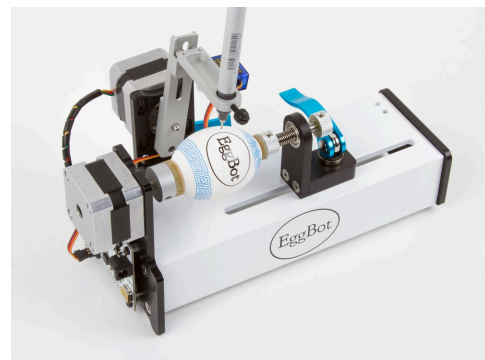

In 2024, Evil Mad Scientist joined forces with Bantam Tools and in 2025 brought out the Bantam Tools EggBot™ with the same easy to use open geometry in an elegant folded metal frame. It uses the new Bantam Tools Studio software, and allows easy file transfer via MicroSD card.

Left: Bantam Tools EggBot™, 2025

## Part 1: Checking out your Bantam Tools Bantam Tools EggBot™

### Box contents

1. Bantam Tools Bantam Tools EggBot™
2. Frosted Glass Ornament

### Accessories & Tools

3. Black Ultra Fine Point Sharpie
4. 2.5 mm Hex Key
5. Bantam Tools EggBot™ Pen Height Setup Tool
6. SD Card
7. 9V 1.5A Power Supply



## 1.2 Anatomy

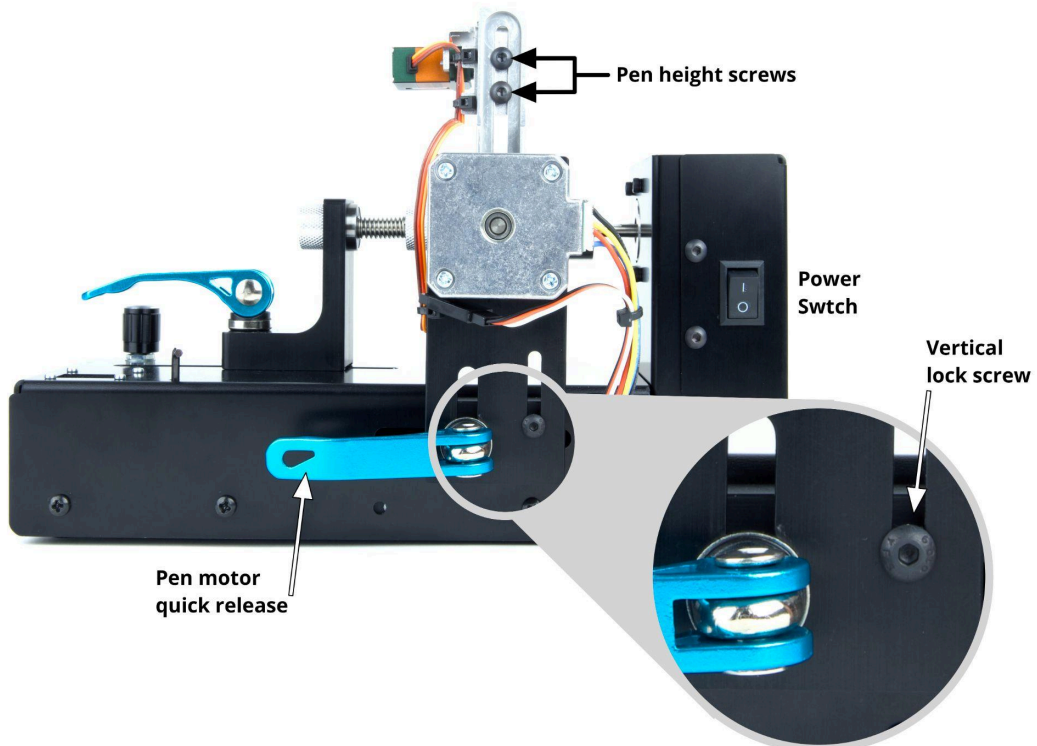
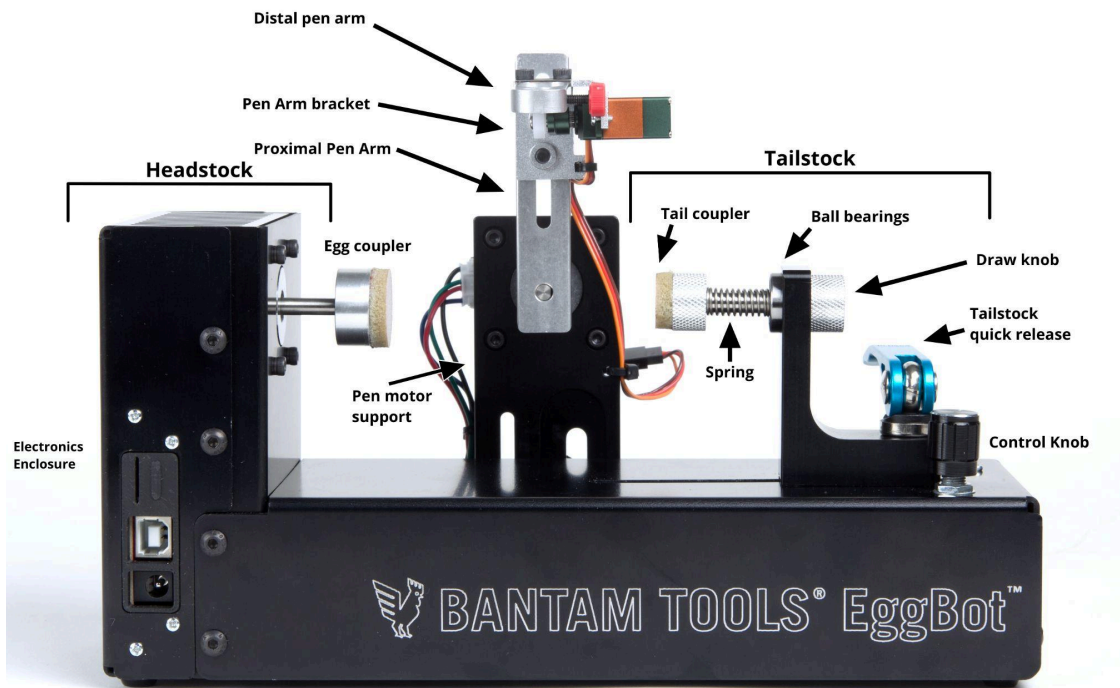

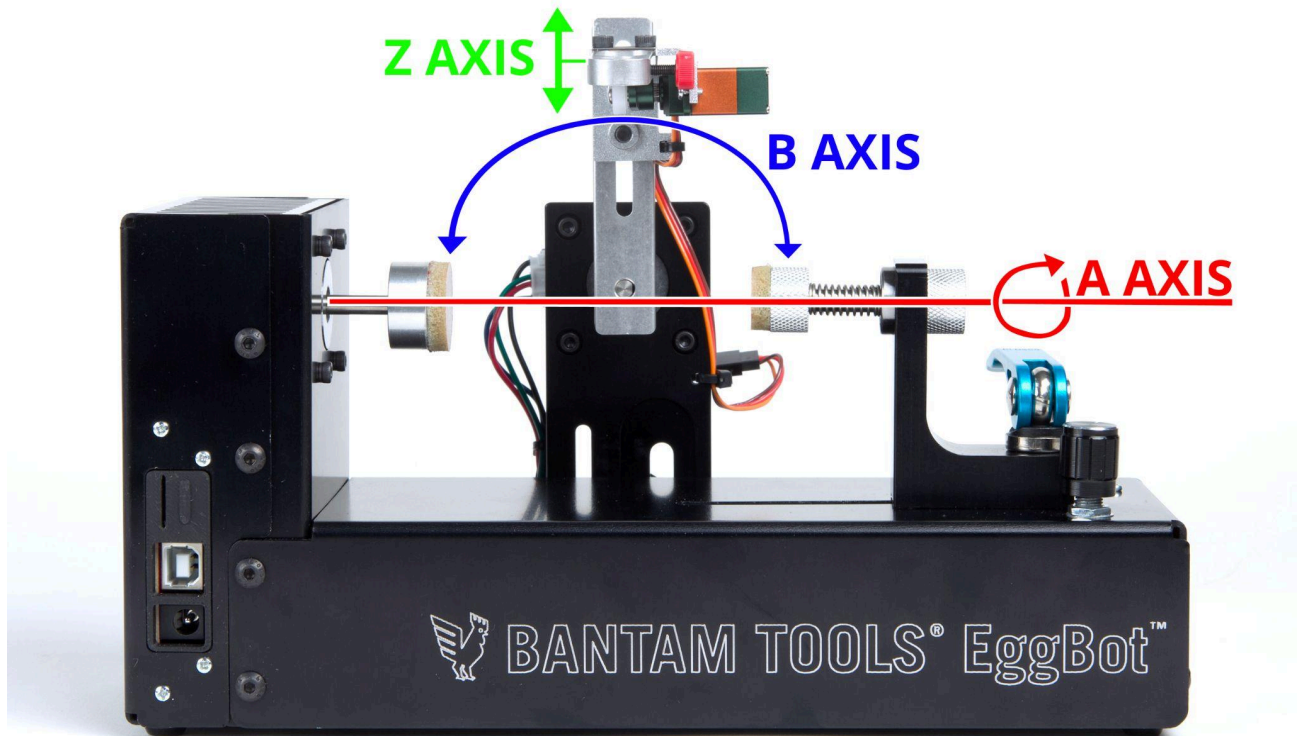
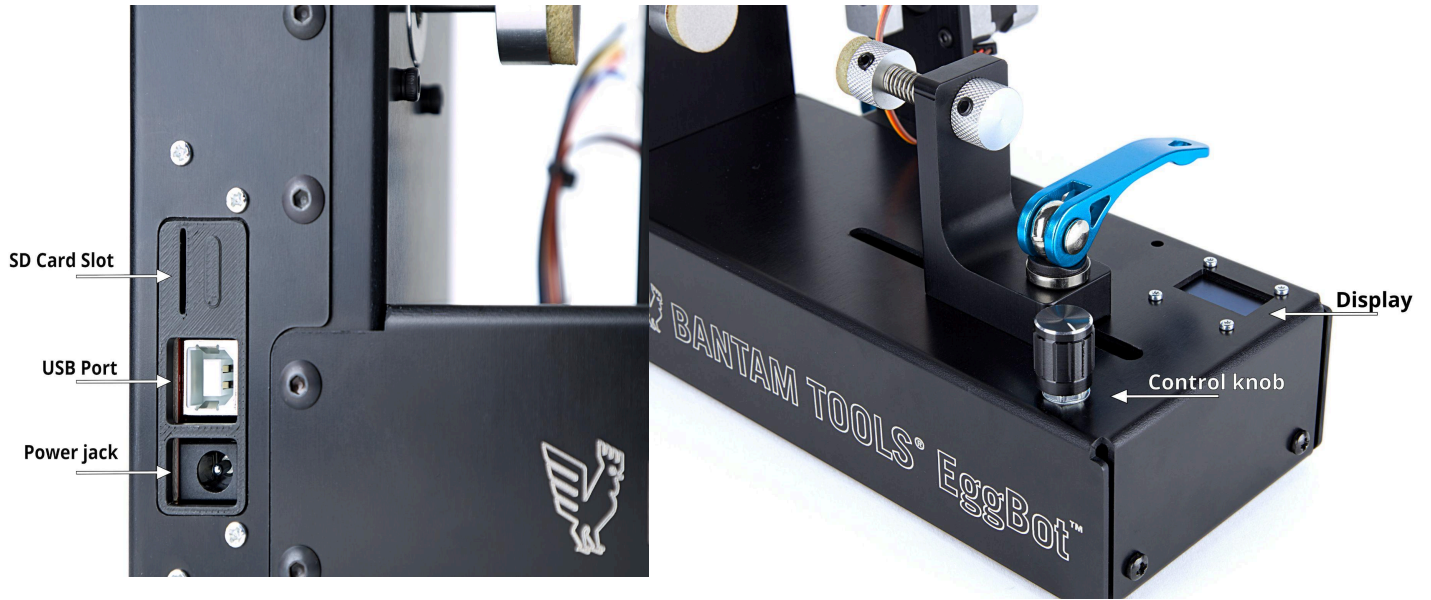

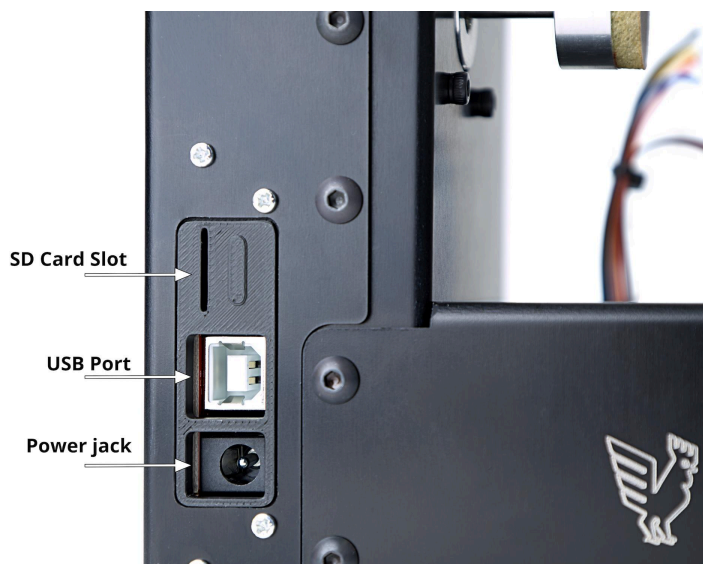
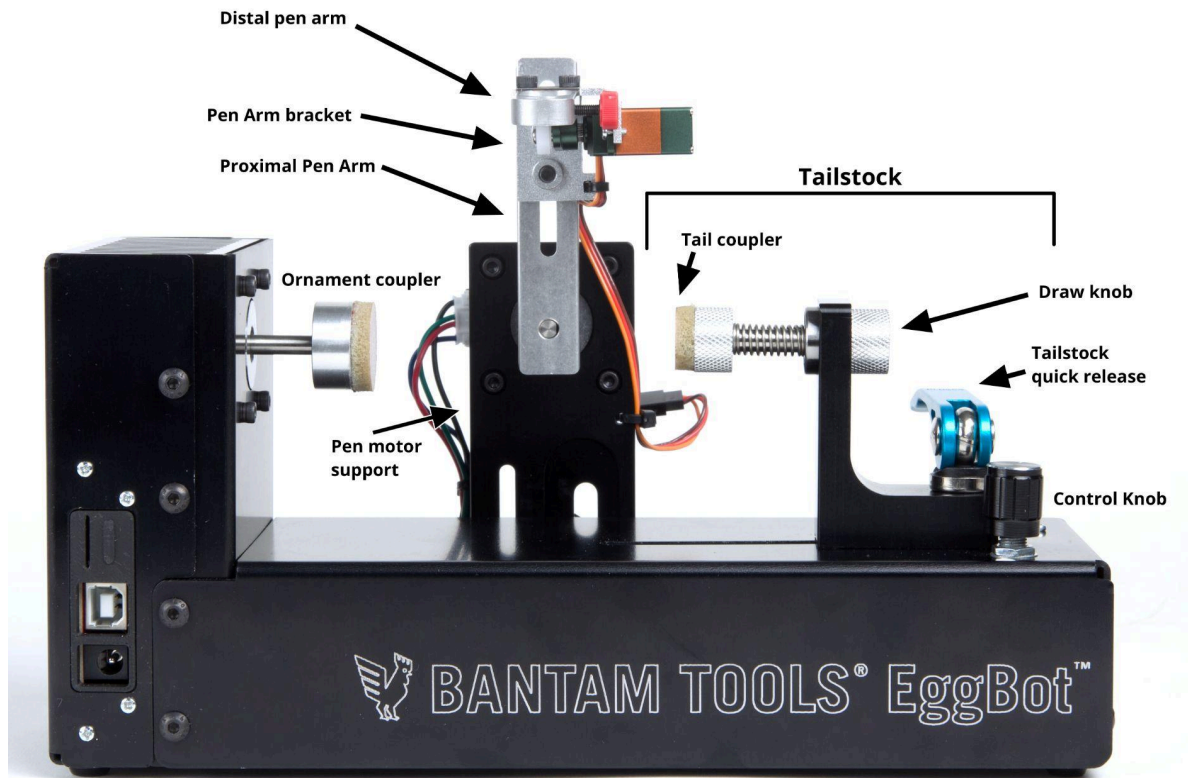

## 2. Quick Start: Your First Ornament

The Bantam Tools Bantam Tools EggBot™ Ornament Edition comes pre-tested and ready to draw using the included **67 mm glass ornament**. This part of the guide will walk you through setting up the machine and drawing the provided sample files.

## 2.1 Step 1: Power On

Plug in the included AC Power Cable and turn on the machine using the power switch on the back left side of the machine.

## 2.2 Step 2: Unlock The Motors

Use the **Control Knob** to scroll to the **Lock Icon**.

Press the **Control Knob** to unlock.

Your screen should read **(Motors Off)**.



## 2.3 Step 3: Remove the Ornament Top

Gently pull the wire loop straight out. This will release and remove the ornament top. Set it aside.

Note: Depending on the ornament you might find it helpful to place the crown back on once the wire is removed.

## 2.4 Step 4: Insert and Center Your Ornament

Place the ornament between the couplers, then spin it manually to fine-tune centering. As you rotate it, check the top position of the ornament—it should stay level. If it wobbles up or down, move it toward the higher point and nudge it down gradually until the motion is steady. (see section 6.2, Page 23, for more assistance on centering)

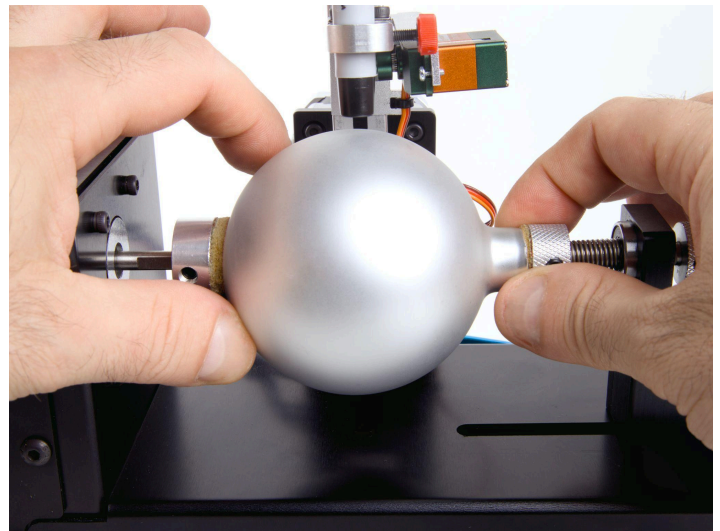

## 2.5 Step 5: Center

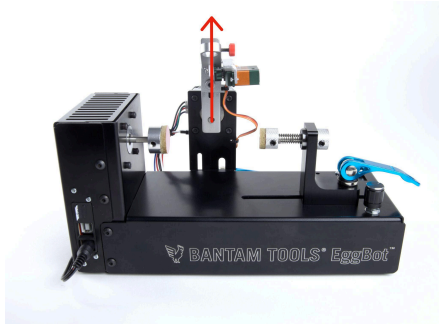

Bring the **Pen Arm** to center so it's in a neutral position for drawing.

## 2.6 Step 6: Lock the Motors (Home)

With the Pen Arm Back in the center, use the **Control Knob** to scroll to the **Lock Icon** again and press to lock.

Your screen should now read **(Motors On)**.



## 2.7 Step 7: Browse Files



Use the **Control Knob** to select **Browse Files**. Included on the machine will be a selection of demos and featured art from Artists.

Press the knob to open the list of available files.

***Tip:** Selecting a file won't start drawing yet, it simply moves the machine into position so you can insert your pen.*

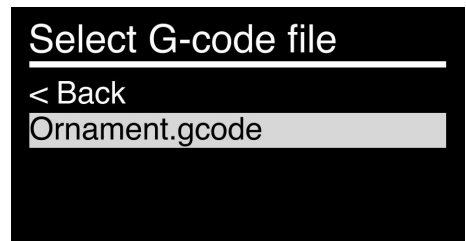



## 2.8 Step 8: Insert the Pen

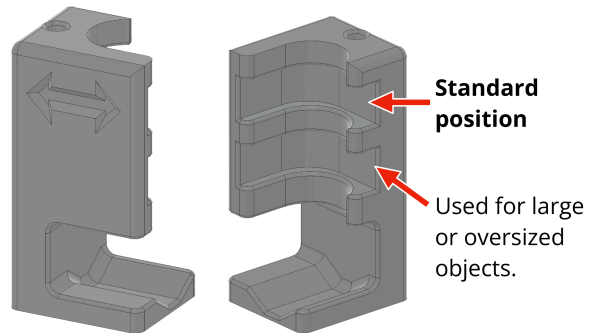

Your screen will display the color requested by the file. In the example above you can see that it says “Black - Sharpie - UltraFine”. Now grab the included **Pen Height Setup Tool**. For the included **67 mm glass ornament** or anything smaller use the standard (upper) position.

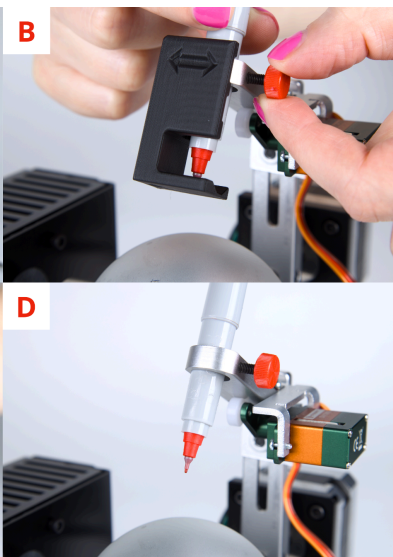

**A.** Slide the Pen Height Setup Tool onto the tip of the Pen Holder from the left as shown.

**B.** Insert your pen so the tip touches the bottom of the tool. Tighten the screw.

**C & D:** Carefully remove the Pen Height Setup Tool.

**You're ready to start drawing!**  
**Press the Control Knob and watch it go.**

**Tip:** *If your design includes multiple colors, the screen will display which color to use next. Remove the current pen, then repeat the pen setup process for each new color.*

## 2.9 Step 9: Reattach the ornament top

When your drawing is complete, remove the ornament and place the ornament top with the wire positioned in the lower indentation of the cap. Hold the cap against the ornament and press the wire back in to secure the top.



## 3. Bantam Tools Studio *Preparing Your First Design*

### 3.1 Designing your SVG

**Canvas Size:** Start by opening your favorite SVG editor, such as Inkscape, Illustrator, Figma, or Pixelmator, and creating a new document. Set your document size to 360 mm wide by 90 mm tall. This represents the full 360° wrap-around width of the ornament and 90° of vertical travel along the B axis. Even though your editor uses millimeters, these values correspond to 360 degrees by 90 degrees in rotational space. You'll also notice that the aspect ratio of 360:90 is equal to 4:1.

Note:

SVG files are infinitely scalable inside Bantam Tools Studio, so exact size isn't critical. Bantam Tools Studio uses **96 DPI**, so if you're working in Illustrator, you can adjust your DPI for accurate scale, but it's not required.

The actual circumference of the ornament is 210mm, so if you want to maintain the same aspect ratio, but be able to visualize accurate-ish stroke widths, you can set your canvas to 210mm wide by 52.5 tall.

**Design Tips:** The Bantam Tools EggBot™ is designed to draw **paths**, or continuous lines, not bitmap images or filled shapes. Make sure your artwork consists of stroked paths only. Objects such as circles, rectangles, and lines are already paths, but outlined text or complex shapes may need to be converted to paths before plotting.

Note:

In the same way that a map relates to a globe, so your design will relate to the final drawing on a sphere. The lines will converge as they get closer to the "north and south poles" of the ornament.

**Multi-Color:** There's no need to separate colors into layers. Bantam Tools Studio automatically detects colors within your SVG and helps you assign pens during setup. We'll cover color, layer, and group management in a later section.

**Fills:** If you'd like to create filled areas, use evenly spaced strokes instead of traditional fills. You can do this by using a hatch fill pattern. **Hatch Fill** can be installed by downloading the **Bantam Tools NextDraw Extensions** from [bantam.tools/ndsoft](https://bantam.tools/ndsoft). It comes as part of the **NextDraw Extension** located in the **Bantam Tools Utilities** folder found in Inkscape under the **Extensions** tab.

You can also design directly on an iPad using our [Bantam Tools Draw](#) app, which includes built-in templates and is optimized for creating pen-plotter drawings with an **Apple Pencil**.

When your design is ready, **export it as an SVG**, and let's head over to **Bantam Tools Studio** to prepare your plot.

## 3.2 Preparing your own G-code

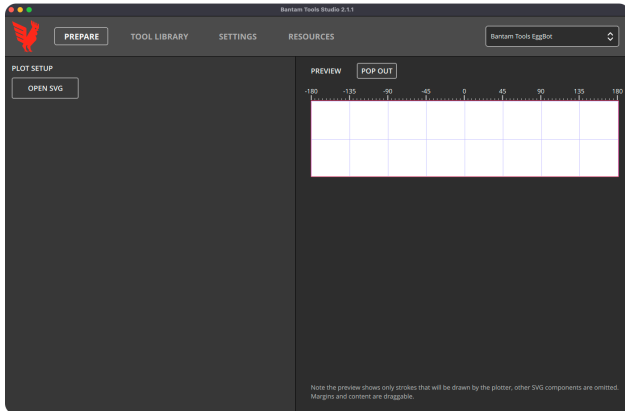

When you first open Bantam Tools Studio, select **Bantam Tools EggBot™** as your machine.

If you have multiple machines connected, you can switch between them using the menu in the top right corner.

You should already be on the **Prepare** tab. Select **Open SVG**, browse to your design, and open it.

### Media Settings:

This will default to 360 × 90 degrees.

This area represents the full 360° wrap-around width of the ornament and 90° of vertical travel along the B axis.

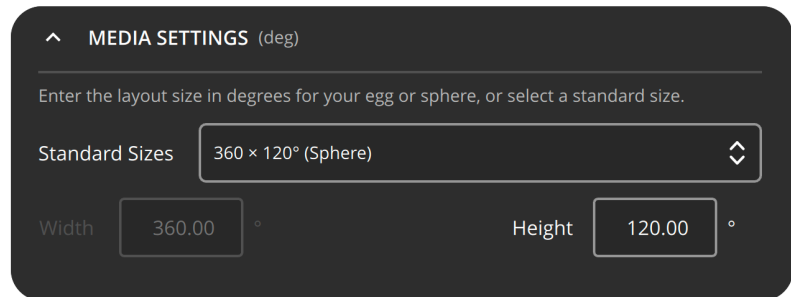

When designing in an SVG editor, continue to use millimeters (360 × 90 mm), but understand that these values correspond to 360 degrees by 90 degrees in rotational space.

We use this convention to make 3D spherical forms easier to design in a 2D workspace. In our testing, some larger spheres can handle increasing the B axis to 120 degrees, but doing so increases the risk of the pen contacting the ornament holders.

### Artwork Settings:

Use these controls to center and scale your design.

**Tip:** Double-clicking your art in the preview window will automatically center it.

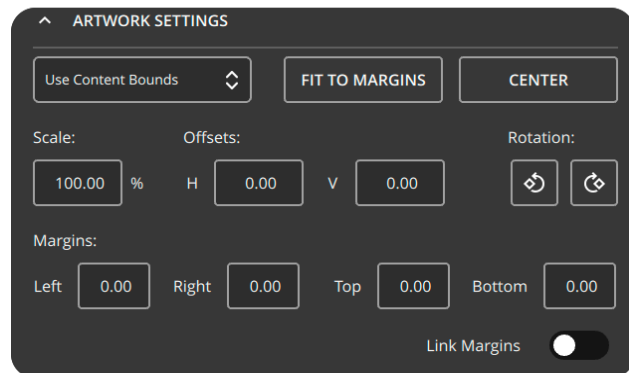

## Tool Settings:

Here you'll select which pens will be used for each color, layer, or group.

Start by selecting a **Toolset**. This defaults to **Sharpie – Ultra Fine**. We've spent a lot of time refining the Sharpie Ultra Fine settings, and they also work well with other felt-tip markers such as Microns and Stabilos.

You can sort strokes by **Color**, **Group**, or **Layer**.

For most Bantam Tools EggBot™ projects, sorting by **Color** works best.

You can use **Auto Assign Tools** to match pens to the colors found in your SVG.

Depending on the color palette used in your design, you may need to adjust these assignments manually. You'll notice that the above example has matched the Neon Green color in the SVG to the Light Green Sharpie UltraFine pen. This matching feature is a time saver to help you connect the colors in your svg with the available colors in your toolset.

To fine-tune or hand-select pens, go through each color and choose the pen you want.

When you're ready, go to the top right corner and select **Generate and Save G-code**. Move the resulting `.gcode` file onto your SD card, and you're ready to plot your design. You'll be prompted to save the setup sheet which will create a pdf with all your settings. This is useful if you think in the future you'll want to recreate your artwork using the same settings.

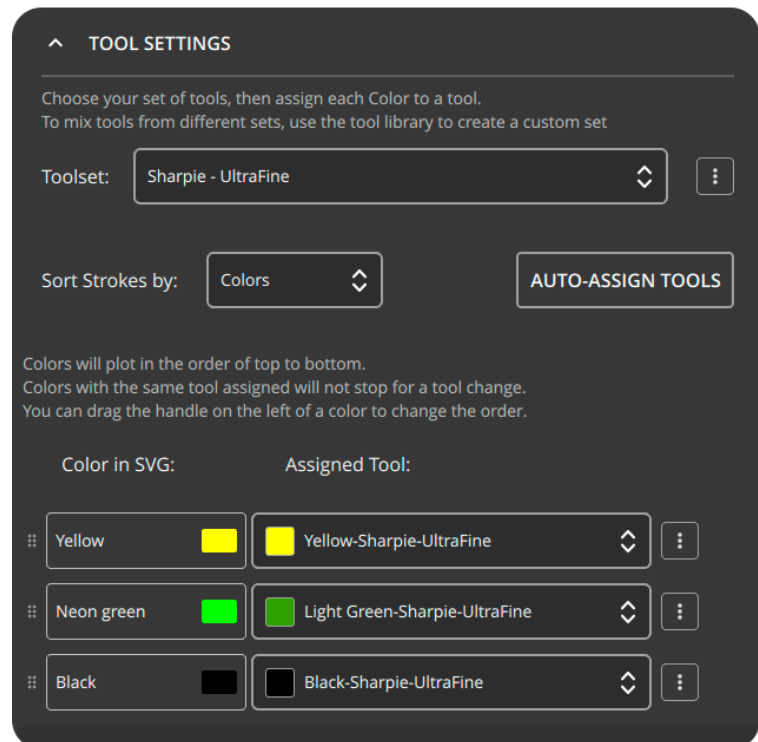

### 3.3 Quick Changing Settings

The quickest way to change your settings is to edit an existing toolset.

From the **Prepare** tab, in the **Tool Settings** section, select the three dots next to one of the pens, then click **Quick Edit Tool**.

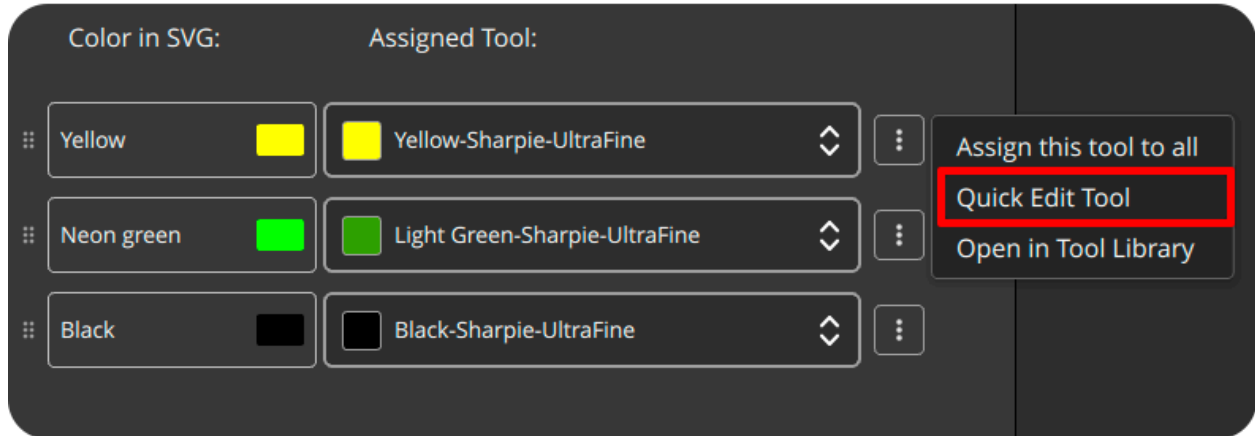

From here, you can adjust the tool's parameters. A common change is increasing or decreasing the XY feedrate to improve precision or speed up plot times. After entering your new value, select **Create New Toolset With These Settings**.

**Note:** Default tools can be edited within the current file, but any changes will revert when the file is closed. To preserve your adjustments, select **Create New Toolset With These Settings** to generate a copy that you can edit and save permanently.

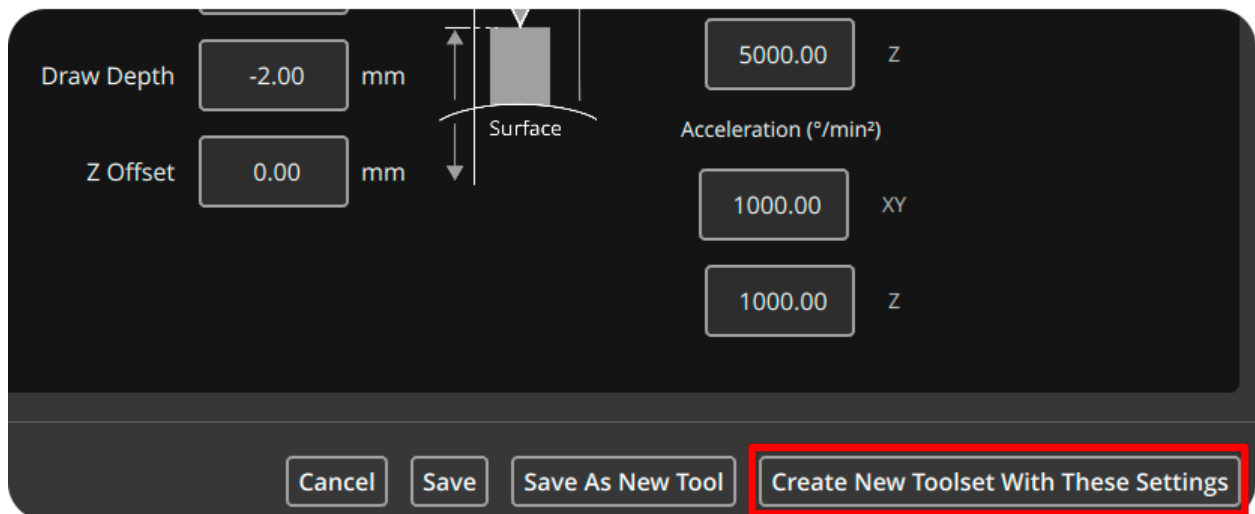

You'll see a summary of the parameter changes and be prompted to name the new toolset. Save it by selecting **Copy Toolset**.

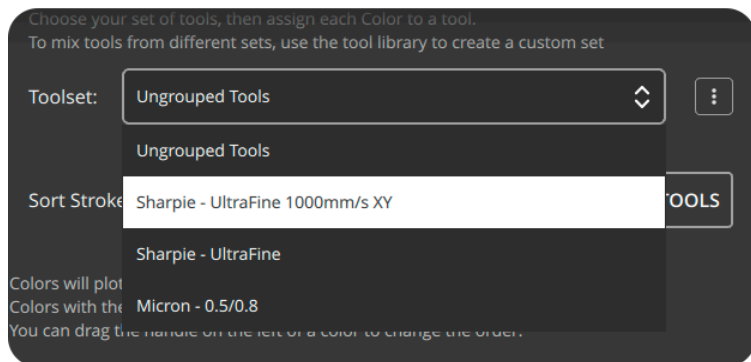
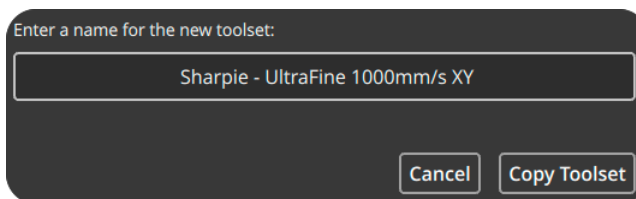

Your new toolset will now appear in the **Toolset** dropdown. You'll notice this toolset name has been modified to mention the change made to the speed. It has been updated with the speed of 1000mm per second in the A and B feedrate (see axis diagram on page 4).

To make further edits, open the **Tool Library** tab. You'll find your custom toolset listed under **User Toolsets**.

- Click the top level of the toolset to edit settings for all pens at once. You'll notice the green box surrounds the entire toolset.
- Click an individual pen to edit its specific settings and name. You'll notice just the individual pen gets surrounded by a green box.

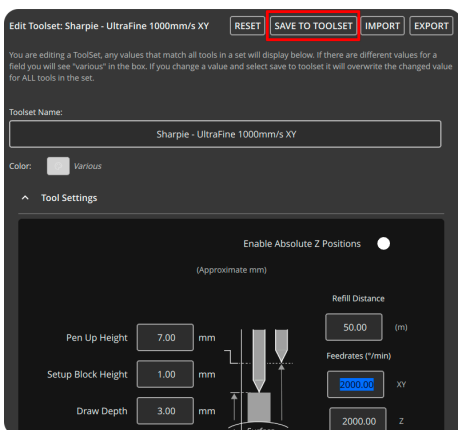
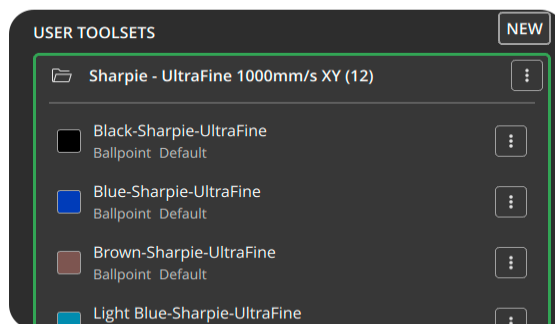

When you're finished, click **Save to Toolset** in the top-left corner of the Edit Toolset window.

## 4 - Creating Your Own Toolsets

From the **Tool Library** window, you can manage and create new toolsets.

1. In the **User Toolsets** section, click **New**.

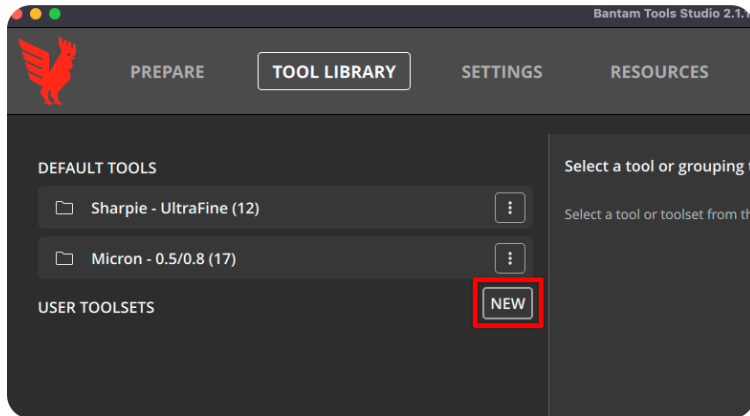

2. Give your toolset a name and select **Create Toolset**.

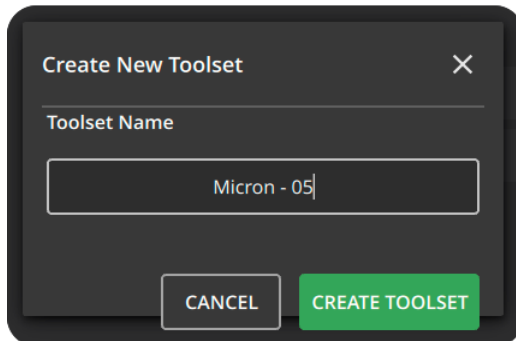

3. Your new toolset will appear under **User Toolsets** in the library. To add tools, click the three dots next to your toolset and select **Add Tool**.

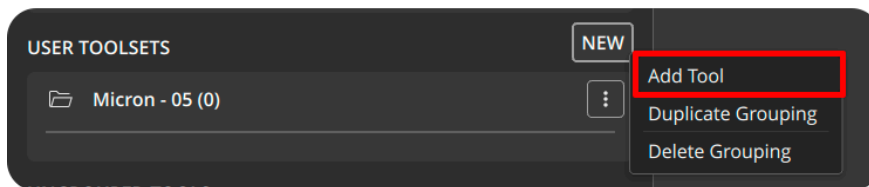

**Tip:** Pens from the same manufacturer typically share similar settings. Start by naming each tool and assigning a color. Once all tools are added, select the entire toolset and apply shared settings. After that, adjust any exceptions, such as colors that might need slower speeds. Remember to hit **Save To Tool** to lock in your settings.

## 4. Setting Up Larger or Smaller Spheres

**Prerequisite:** This guide assumes you've completed **Quick Start: Your First Ornament** and know the basics of running the **Bantam Tools Bantam Tools EggBot™**.

The Bantam Tools EggBot™ comes pre-configured for the included **67 mm glass ornament** (available in packs of 8 in our online store). If you'd like to use a sphere of a **different size**, you'll need to make a few physical adjustments. Follow the steps below to configure your machine for **larger or smaller spheres**.

The Bantam Tools EggBot™ supports a wide variety of round objects, such as holiday ornaments, golf balls, ping-pong balls, lacrosse balls, cricket balls, and baseballs. **This guide covers** the adjustments needed for perfectly **round objects**. For **egg-shaped (ovoid)** items, **see our guide for Setting Up Eggs (Ovoid Shapes)**.

### 4.1 Step 1: Adjust the Tailstock

Hold your sphere up to the machine to get a sense of fit.

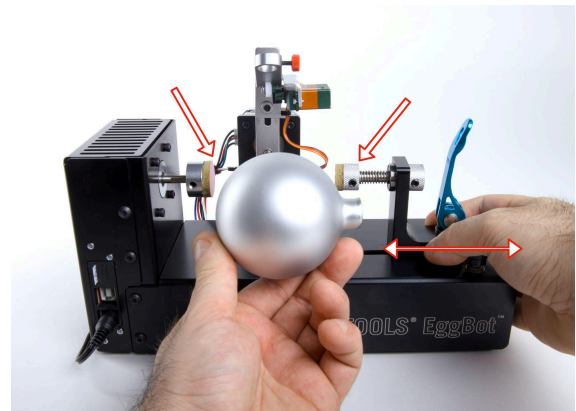

**For larger spheres:** Move the **Tailstock to the right** to open up space and hold the sphere securely in place.

**For smaller spheres:** Move the **Tailstock to the left** to bring the couplers closer together.

You want the sphere to fit **snugly**. Make sure the tip of your sphere extends slightly beyond the Tail Coupler so the spring can be pulled back to insert it. When released, the spring will compress and hold the sphere firmly.

Once mounted, use the technique covered in **Quick Start: Your First Ornament** to rotate and **center the sphere on the X axis**.

## 4.2 Step 2: Recenter the Pen Motor

Changing sphere size shifts its centerline. You'll need to recenter the pen motor so your drawing remains balanced and aligned.

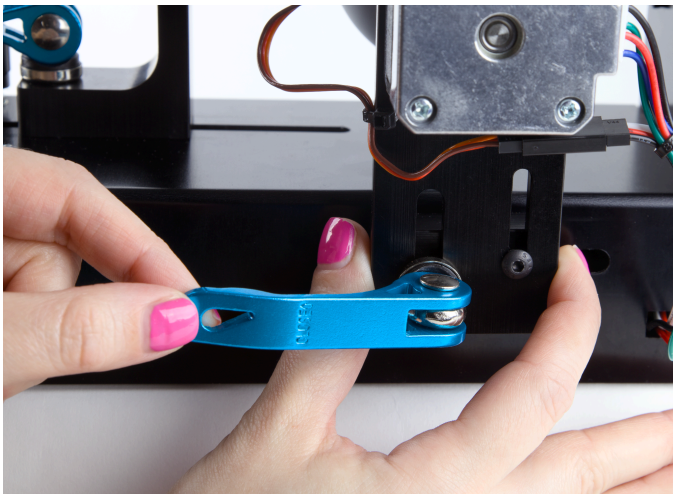
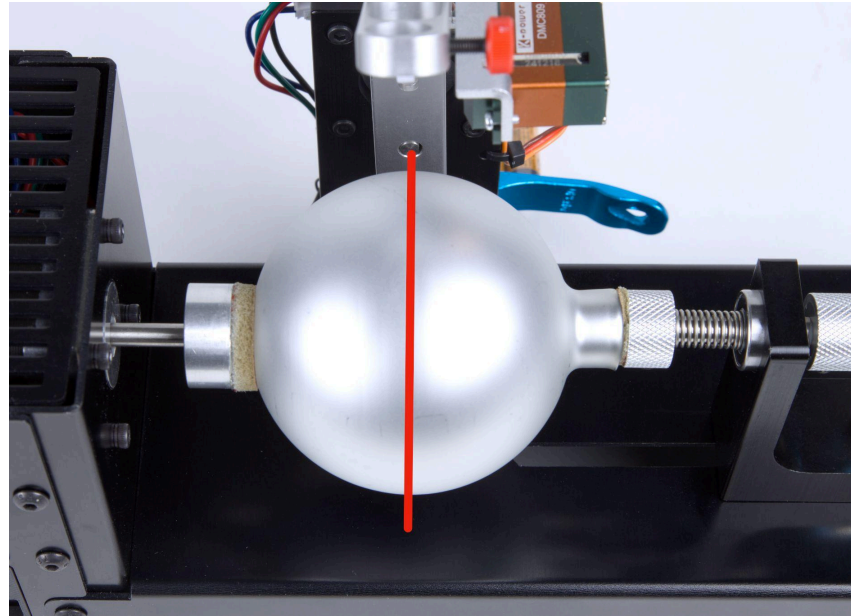

**For larger spheres:** The centerline moves outward. Release the Quick Release and slide the **Pen Motor Support to the right** until the motor is centered with the sphere.

**For smaller spheres:** The centerline moves inward. Release the Quick Release and slide the **Pen Motor Support to the left** until centered.

**Tip:** Insert a pen and move the Y Arm left and right. The pen should maintain the same clearance above the sphere across the full range of motion. This confirms proper centering and ensures the pen maintains consistent contact during plotting.

### 4.3 Step 3: Adjust the Pen Height

The pen arm must stay level with the sphere's centerline to ensure a true 90° writing angle.



Slide the Pen Setup Height Tool onto the Pen Arm. Use the standard (upper) position of the tool for most spheres. If your sphere is especially large, use the lower rung of the tool to ensure proper clearance.

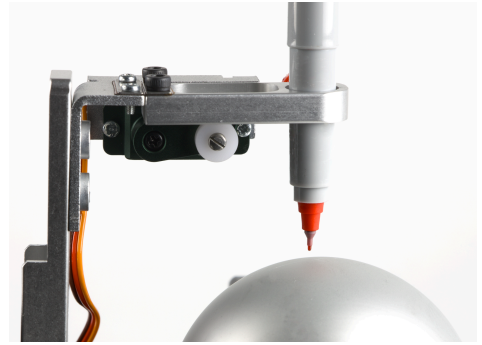

**With the power off**, use the included 2.5 mm hex wrench to loosen the two bolts at the back of the Pen Arm Bracket.

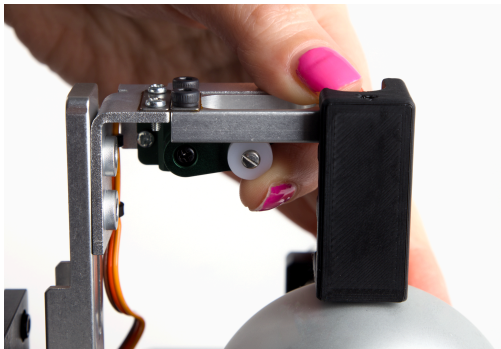
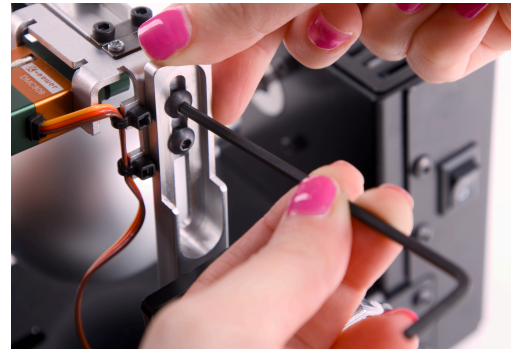

Hold the Pen Lift flat against the Servo Bracket so the Pen Arm is level at a 90° angle to the top of your sphere.

Straighten the Pen Arm, then tighten both 2.5 mm bolts.

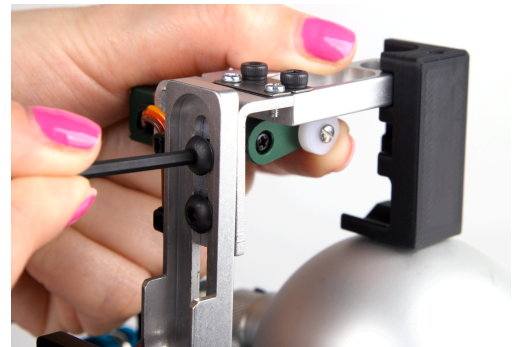

### 4.4 Step 4: Test and Plot

**Test:** see section 6.2, Page 23, for **troubleshooting centering and pen motor support alignment**.

You're now ready to start drawing at this new size. Each time you change ornament size, repeat these steps to ensure proper centering and pen alignment.

**Note:** Ovoid shapes like eggs require one additional calibration step. See the next section for **Calibrating for Eggs**.

## 5. Setting Up Eggs

**Prerequisite:** This guide assumes you've completed **Quick Start: Your First Ornament** and know the basics of running the **Bantam Tools EggBot™**.

Because eggs have an asymmetrical shape and shifted centerline, they require additional calibration steps compared to spheres. We recommend first practicing with **larger and smaller spheres** to get comfortable with centering, pen height, and pen motor adjustments before moving on to eggs, which build upon those same principles with a few extra alignment steps.

---

### 5.1 Step 1: Adjust the Tailstock

Hold your egg up to the machine.

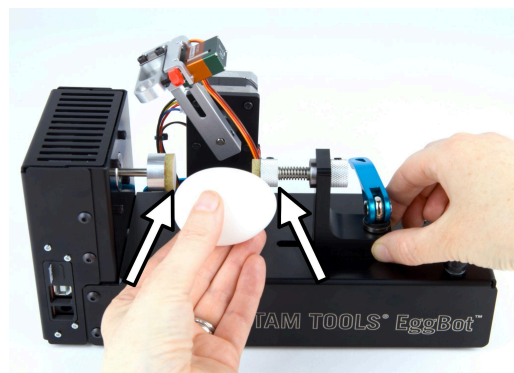
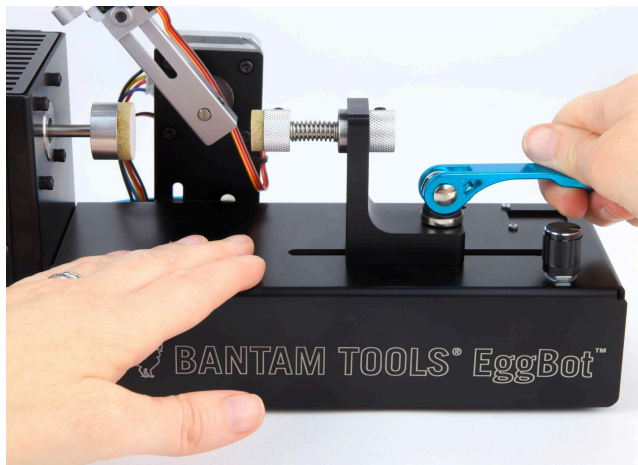

To accommodate the shape, move the **Tailstock left or right** as needed until the egg is held securely between the couplers. You want the fit **snug**, with slight compression from the spring so the egg is firmly held but not under stress.

Use the centering technique covered in **Quick Start: Your First Ornament** to rotate and **center the egg on the X axis**, ensuring smooth and centered rotation.

### 5.2 Step 2: Recenter and Set the Motor Height for Eggs

Eggs have a shifted centerline and a more elongated curvature than spheres, so you'll need to first recenter the motor horizontally, then adjust its vertical position to match the egg's shape.

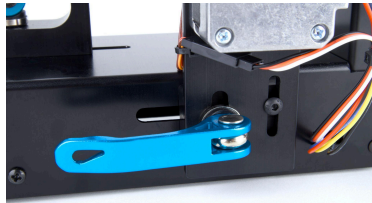
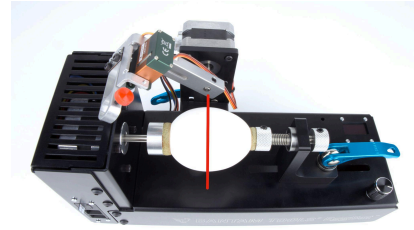

### 5.2.1 Recenter the Pen Motor

Release the QuickRelease and slide the **Pen Motor Support** **left** or **right** until the motor is centered with the egg's **widest point**. This keeps your drawing balanced and aligned around the true rotational axis of the egg.

### 5.2.2 Set the Pen Motor Vertical Position

Use the included **2.5 mm hex wrench** to slightly loosen the bolt that locks the **Pen Motor Support** vertically.

Lower the support to the appropriate height, then re-tighten the bolt:

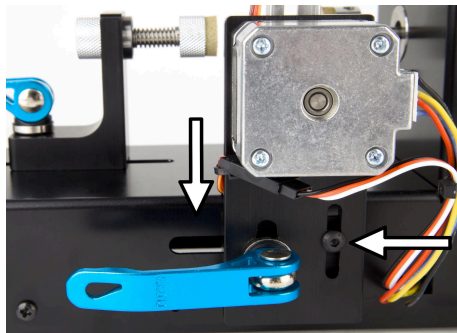
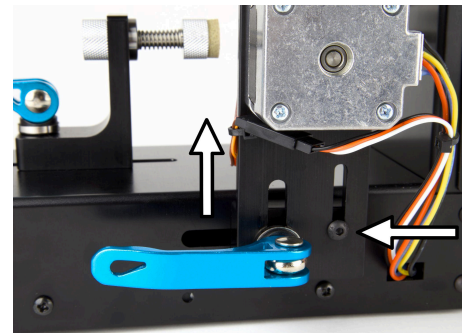

(Above) **Full up = Spheres** (e.g., glass ornaments)

(Left) **Halfway down = Chicken eggs**

(not shown) **Lower positions = More elongated eggs** (e.g., turkey eggs)

Adjusting the motor vertically changes the pivot height of the pen arm, compensating for the egg's elongated shape so that the pen follows a more **elliptical arc** rather than the circular path used for spheres.

**Tip:** After adjusting, insert a pen and move the Y Arm left and right. The pen tip should maintain consistent clearance across the surface. This confirms your egg is properly centered and that the pen motor's pivot matches the curvature of the object.

## 5.3 Step 3: Adjust the Pen Height

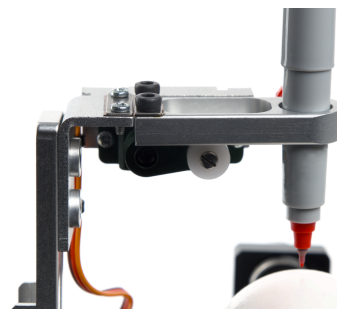

The pen arm must stay level with the sphere's centerline to ensure a true 90° writing angle.

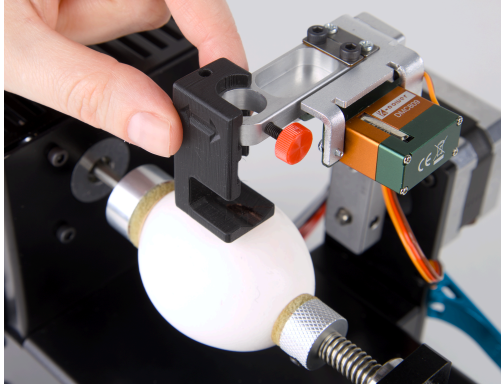

Slide the Pen Setup Height Tool onto the Pen Arm. Use the standard (upper) position of the tool for most Eggs.

With the power off, use the included 2.5 mm hex wrench to loosen the two bolts at the back of the Pen Arm Bracket.

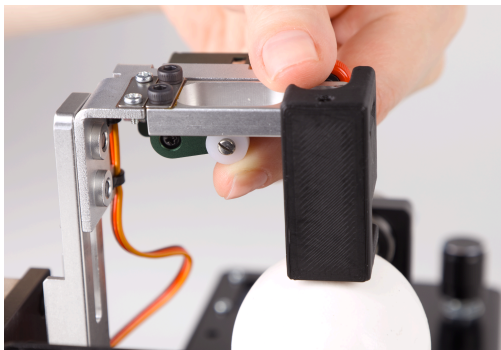
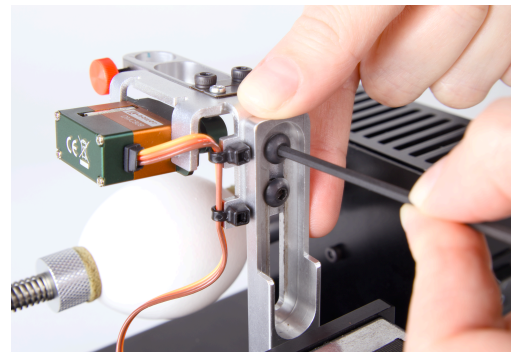

Hold the Pen Lift flat against the Servo Bracket so the Pen Arm is level at a 90° angle to the top of your sphere.

Straighten the Pen Arm, then tighten both 2.5 mm bolts.

## 5.4 Step 4: Test and Plot

**Test:** see section 6.2, Page 23, for **troubleshooting centering and pen motor support alignment.**

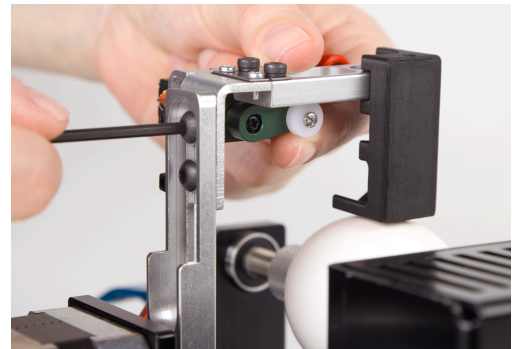

You're now ready to start drawing on eggs. Each time you change sphere / egg size, repeat these steps to ensure proper centering and pen alignment.

## 6. Tips, Tricks and General Operation

**Tool Storage:** A small hole in the right rear corner of the body provides convenient storage for the hex driver. The Pen Height Setup Tool has a matching hole, allowing you to slide the hex driver through it and store both together in the same spot.

**Egg Preparation:** For eggs, leave them out overnight or warm them in lukewarm water, then dry before drawing. Condensation interferes with most pens.

**Egg Handling:** We recommend decorating whole raw eggs. If the results are not good, crack and cook. If the results are good, you can blow the egg and still cook the contents. If you hard boil first, you cannot keep just the shell. (See egg blowing instructions below.)

**Orientation:** Coordinate orientation: when printing, the top of your drawing faces the tailstock, and the bottom faces the headstock. The origin is at the center. This makes it natural to place the fat end of an egg or the base of a glass ornament toward the larger spindle coupler. If you need the opposite orientation, rotate the artwork in Artwork Settings before saving G-code.

**Angular Mapping:** 1 mm corresponds to 1°, so 360 mm equals one full spindle rotation. A vertical value of 90 mm equals 90°, one quarter turn of the pen motor. The actual printable height depends on object shape and pen.

**Setup Check:** Once set up for a given object type, little per-object setup is needed. Manually spin to confirm centering.

**Geometry Compensation:** Egg geometry can visually stretch graphics. Consider horizontal stretch to compensate. For chicken eggs, a 150 percent horizontal stretch is a good starting point.

**Pause and Resume:** To pause a plot during drawing, press the knob. Press again to resume.

**Pen Compatibility:** Many marking tools work if they fit the holder.

**Extended Length Trick:** Default maximum object length is about 4.5 inches. Up to about 6.25 inches may fit by reversing the tailstock and spring plunger. Lock the quick release before reattaching the draw knob.

**Cleaning:** Use a soft, clean cloth. For non-electronic metal parts, a cloth moistened with mild soap and water is acceptable. Avoid other cleaners and solvents. Do not wet motors, cables, or the controller. Bearings and quick release pins are greased; avoid degreasing.

## 6.1 Using and Adjusting the quick releases

There are two quick releases, at the tailstock and at the pen motor support. Move the handle to vertical to release, horizontal to tighten. Do not go past horizontally. Always use two hands.



To adjust tension (left): open the handle, turn the blue nut on the inside no more than 1/8 turn, close and test.

## 6.2 Troubleshooting Centering and Pen Arm Alignment

*This section will help you diagnose and correct uneven pen alignment or sphere wobble to ensure smooth, consistent drawing.*

Make sure that the pen tip has a fairly consistent height above the surface, over the entire range of travel, like so:



If it does not, you may need to fine tune the alignment:



Move pen arm closer to tailstock §3.3



Move pen arm closer to headstock §3.3



Lower pen motor vertically §3.4



Raise pen motor vertically §3.4

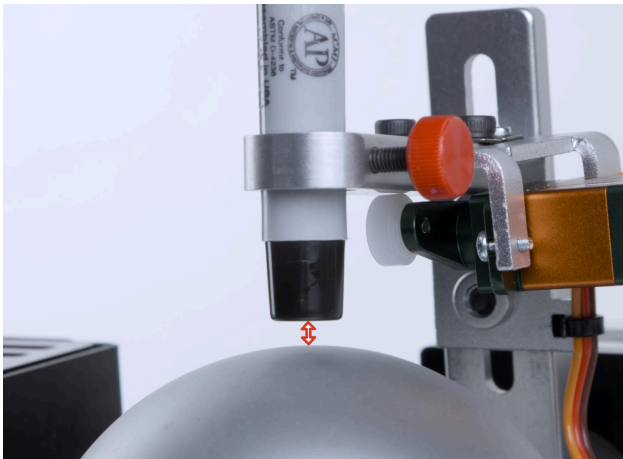

### Adjust Pen Arm Height

If the left side of the pen arm sits higher than the right and your sphere is already centered, adjust the centering of the pen arm itself. The goal is to maintain an even pen-over height as the arm moves back and forth.

### Check for Wobble

**With the machine off**, gently spin the ornament by hand. Use the tip of a pen or the body of a Sharpie as a reference point to check for wobble and measure the gap between the pen and surface. Adjust the position until the spacing stays consistent throughout rotation and the wobble disappears.

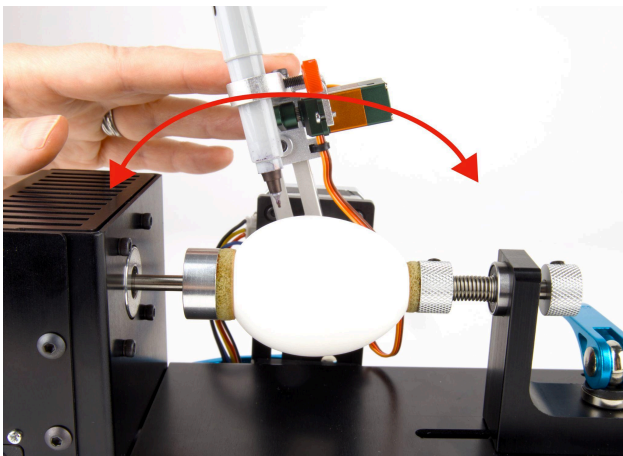

### Fine-Tune for Eggs

This adjustment is especially useful when drawing on eggs, which often have an **off-axis equator** or are **not perfectly symmetrical along their rotational axis**. Ensuring consistent pen height across the arm's range of travel will improve line quality and reduce uneven pressure.

## 6.3 Using your own G-code

The Bantam Tools Bantam Tools EggBot™ reads and interprets G-code. Bantam Tools Studio is designed to generate safe, machine-bounded code for a wide range of pens and tools. You can run manually created or third party G-code, but the risk of out-of-bounds motion increases. The firmware has safety stops, however we recommend external code only if you are confident you will keep motion within bounds.

Tip: Generate G-code with Bantam Tools Studio, then open it in a text editor to study common commands and syntax.

### Coordinate system

- A axis: spindle rotation
- B axis: pen motor rotation
- Z axis: pen lift

Zero is at the center of the work area, where the pen is vertical. Motion commands are typically in G53 machine coordinates, selected at boot. Z travel positions are nonnegative; negative Z is out of bounds.

### About the controller and firmware

The control board is the Bantam Tools Serama Hen, running a fork of the open source FluidNC firmware tailored for this hardware. The open source repository for our fork is linked from our support site. Unmodified FluidNC is not supported on the Bantam Tools EggBot™ platform.

### Supported and tested G-code and custom commands

#### Parameters

- Axes: X, Y, Z, A, B
- N: line numbers

#### Words

- F: feed rate

#### G codes

- G0: rapid motion
- G1: motion at feed rate
- G2, G3: arc motion at feed rate
  - I, J, K, R: arc parameters
- G4: dwell
- G20: specify units in inches
- G21: specify units in millimeters
- G53: use machine coordinates
- G90: absolute distance mode

### **M codes**

- M0, M2, M30: pause and program end

### **Comment syntax commands, Bantam Tools FluidNC fork**

- ( Install Tool: value ) displays tool change text on the Bantam Tools EggBot™ OLED
- ( CLEAR ) clears the OLED tool prompt
- ( AccelA: value ), ( AccelB: value ), or ( Accel: value ) sets per axis acceleration

### **Additional G-code commands**

These are supported by FluidNC but are not used by our generator and have not been extensively production tested on Bantam Tools EggBot™.

### **Parameters**

- E: output pin number with M67
- L, P: G10 parameters
- Q: analog level with M67
- T: tool number with M6

### **Words**

- S: spindle speed or laser power

## G codes

- G10: set coordinate system offset
- G17, G18, G19: plane selection
- G28, G30: predefined position
- G38: probing
- G40, G43, G49: tool length offset
- G54 through G59: select work offset
- G91: relative distance mode
- G92: coordinate system offset
- G93, G94: feed rate modes

## M codes

- M3, M4, M5: spindle control
- M6: tool change
- M7, M8, M9: coolant control
- M62 through M65: digital output control  
M67: analog output

## Typical startup routine

Below is a breakdown of a typical start sequence generated by Bantam Tools Studio. It positions Z for loading, displays a tool prompt, returns A and B to zero, then pauses for the operator.

Example:

```
G90 G90 sets absolute positioning
G0 Z3 G0 Z3 raises Z to 3 mm for pen loading
( Install Tool: 1. Layer: Neutral Gray ) Install Tool comment
  prompts the operator on the OLED
G0 A0 B0 G0 A0 B0 returns A and B to zero
M0 M0 pauses until the operator resumes
```